

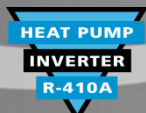

MXS



Multi-Split Heat Pump Systems

EXPERTISE AND INNOVATION

Daikin's 2-port, 3-port, and 4-port multi-split systems can serve up to four rooms from a single outdoor unit. With indoor unit options consisting of streamlined wall mount units, built-in slim duct units, or a combination of both, multi-split systems offer over 1,000 possible connection combinations, creating a flexible, powerful and energy efficient system.

ENERGY EFFICIENCY

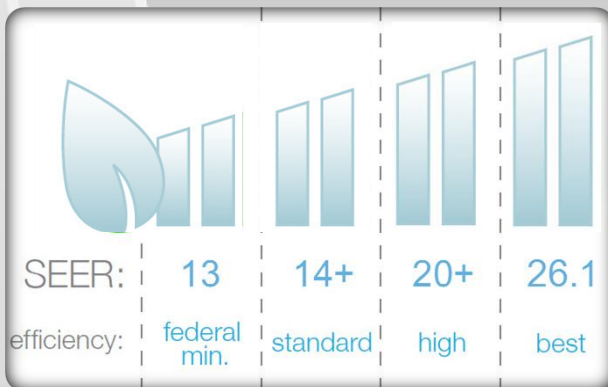

Integrated with an inverter "variable speed" compressor, systems deliver the capacity required to maintain desired room conditions, typically reducing energy consumption by 30% compared to traditional fixed speed systems. This technology minimizes temperature fluctuations and provides continuous cooling and heating comfort with maximum energy savings.

INDIVIDUAL COMFORT AND CONTROL

Equipped with built-in intelligence, each system allows individual room temperature control with the ability to automatically maintain preferences. Systems make subtle and continuous adjustments, ensuring absolute comfort at the touch of a button.



BUILT-IN RELIABILITY



All major components are engineered and manufactured by Daikin, ensuring maximum performance, reliability and efficiency. From the internal motors and compressors to the exterior anti-corrosion treatment and self

diagnostic function, Daikin systems are built with durability and backed by one of the best warranties in the industry.

ADVANCED FEATURES THAT MAKE A DIFFERENCE

See the Difference with Priority Setting Capabilities



Priority Room Settings

During initial installation, a priority room may be set to deliver preferential conditioning and control over the functions: operation mode, powerful operation, and quiet outdoor operation.

Operation mode priority

Cooling or heating operation mode in the selected room is given priority. When a different operation mode from another unit is selected, the unit is placed on standby until the priority room unit stops operating.

Priority during powerful operation

When the priority room is operating in powerful mode, cooling or heating capacities from other indoor units may be temporarily reduced to shift room capacities to the prioritized room.

Quiet operation priority

Quiet operation for the outdoor unit can be initiated by a single command from the priority room controller.

Feel the Difference

Available on wall mount units, the intelligent eye feature detects movement and automatically changes to an energy saving mode when movement is not detected for over 20 minutes. Normal operation resumes once movement is detected, ensuring a comfortable experience with savings up to 20% in cooling and up to 30% in heating.

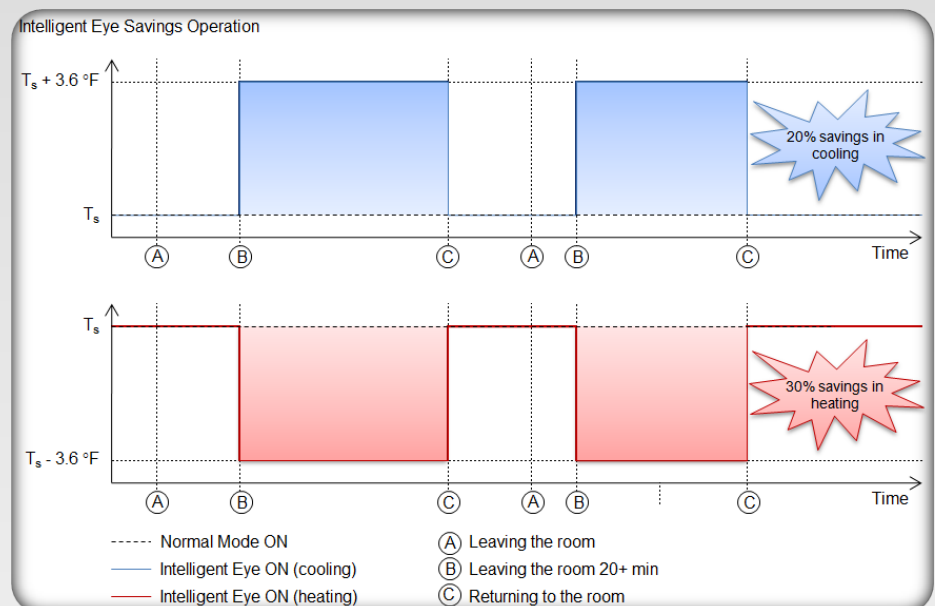

LEADING TECHNICAL PERFORMANCE

Indoor Units - CTXS_HVJU, CTXS_LVJU, and FTXS_LVJU Wall Mounted Units

Model Name		CTXS07LVJU	CTXS09HVJU	CTXS12HVJU	FTXS15LVJU	FTXS18LVJU
Airflow-Wet (H/M/L/SL)	CFM	332/261/194/145	388/335/283/-	388/335/283/-	568/477/385/360	583/484/385/360
Airflow-Dry (H/M/L/SL)	CFM	350/290/233/219	400/357/314/-	400/357/314/-	593/505/417/371	625/526/431/399
Sound Pressure - Cooling (H/M/L/SL)	dB(A)	38/32/25/22	44/40/35/-	45/41/36/-	45/40/35/32	46/41/36/33
Sound Pressure - Heating (H/M/L/SL)	dB(A)	38/33/28/25	44/39/34/-	45/40/35/-	43/38/33/30	45/40/35/32
Piping Connections	Liquid (O.D.)	in.	Ø 1/4	Ø 1/4	Ø 1/4	Ø 1/4
	Gas (O.D.)	in.	Ø 3/8	Ø 3/8	Ø 1/2	Ø 1/2
	Condensate Drain Connection (O.D.)	in.	Ø 5/8	Ø 11/16	Ø 11/16	Ø 5/8
Dimensions (H x W x D)	in.	11-5/8 x 31-1/2 x 8-7/16	11-7/16 x 31-5/16 x 9-3/8		13-3/8 x 41-5/8 x 9-3/4	
Net Weight	lbs.	20.0	20.0	20.0	31.0	31.0

Indoor Units - FDXS_LVJU and CDXS_LVJU Slim Duct Units

Model Name		FDXS09LVJU	FDXS12LVJU	CDXS15LVJU	CDXS18LVJU
External Static Pressure	"W.G.	0.12	0.12	0.16	0.16
Airflow-Wet (H/M/L/SL)	CFM	305/280/260/235	305/280/260/235	424/388/353/297	424/388/353/297
Airflow-Dry (H/M/L/SL)	CFM	305/280/260/235	305/280/260/235	424/388/353/297	424/388/353/297
Sound Pressure - Cooling (H/M/L/SL)	dB(A)	35/33/31/-	35/33/31/-	37/35/33/31	37/35/33/31
Sound Pressure - Heating (H/M/L/SL)	dB(A)	35/33/31/-	35/33/31/-	37/35/33/31	37/35/33/31
Piping Connections	Liquid (O.D.)	in.	Ø 1/4	Ø 1/4	Ø 1/4
	Gas (O.D.)	in.	Ø 3/8	Ø 3/8	Ø 1/2
	Condensate Drain	in.	Ø 25/32	Ø 25/32	Ø 25/32
Dimensions (H x W x D)	in.	7-7/8 x 27-9/16 x 24-7/16		7-7/8x35-7/16x24-7/16	
Net Weight	lbs.	47.0	47.0	60.0	60.0

Outdoor Units

Model Name		2MXS18GVJU	3MXS24JVJU	4MXS32GVJU
Maximum Capacity	Btu/h	18,000	24,000	30,600
Power Supply		Single phase 60Hz 208/230V		
Minimum Circuit Amps	A	11.1	17.8	18.0
Maximum Overcurrent Protection	A	20.0	20.0	20.0
Sound Pressure - (Cooling/Heating)	dB(A)	50/51	52/54	52/54
Operating Range - Cooling	°F DB	14 -115	14 -115	14 -115
Operating Range - Heating	°F DB	5 - 72	5 - 72	5 - 72
Max. Piping Length	ft.	164	230	230
Max. Piping Height	ft.	82	82	82
Max. Piping Height	ft.	49.2	49.2	49.2
Dimensions (H x W x D)	in.	28-15/16 x 32-1/2 x 11-13/16	30-5/16 x 35-7/16 x 12-5/8	
Net Weight	lbs.	139.0	168.0	168.0

Certified Performance Ratings

Outdoor Model	Indoor Model	Capacity 95 °F High	EER 95°F	SEER	High Heat 47 °F	HSPF	Low Heat 17 °F
2MXS18GVJU	Non-Ducted	18,000	12.6	19.5	22,000	9.2	13,500
2MXS18GVJU	Mixed	17,000	10.8	16.3	22,000	8.5	13,300
2MXS18GVJU	Ducted	16,000	9.0	13.0	22,000	7.7	13,100
3MXS24JVJU	Non-Ducted	24,000	12.5	16.6	30,000	9.0	19,300
3MXS24JVJU	Mixed	23,600	11.1	14.8	29,400	8.35	18,600
3MXS24JVJU	Ducted	23,400	9.7	13.0	29,000	7.7	18,100
4MXS32GVJU	Non-Ducted	30,600	10.3	17.2	32,000	9.3	22,200
4MXS32GVJU	Mixed	29,800	9.35	15.25	31,200	8.6	21,600
4MXS32GVJU	Ducted	29,000	8.4	13.3	30,400	7.9	21,000

TIME-SAVING INSTALLATION AND EASE

Connected by a pair of refrigerant lines, few electrical connections, and little to no ductwork, indoor and outdoor units can be easily installed in existing spaces with minor disruption and often in a single day's work. The compact and lightweight designs combined with flexible piping and minimal wiring allow installation with minimal time and costs.

For CTXS09/12HVJU

Space required for installation (in.)

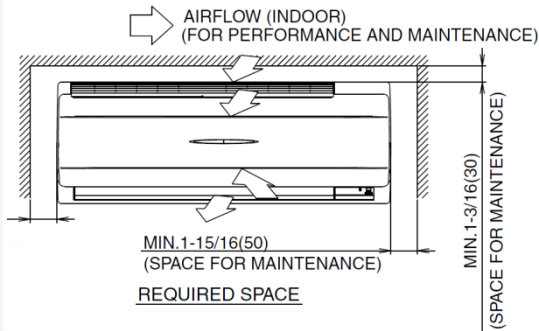

For CTXS07LVJU & FTXS15/18LVJU

Wall height on air outlet side = Less than 47-1/4"

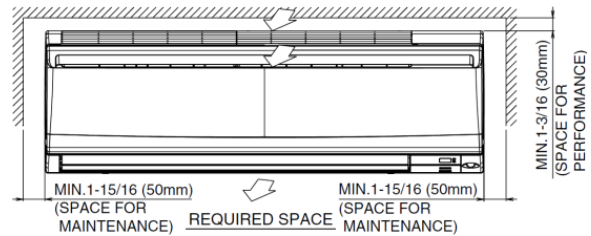

For FDXS09/12LVJU

Space required for installation (in.)

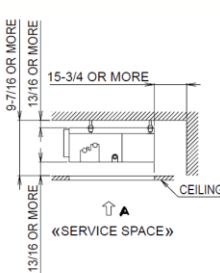
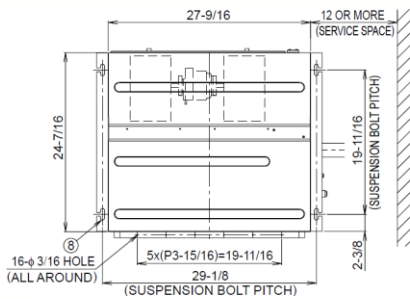

For CDXS15/18LVJU

Wall height on air outlet side = Less than 47-1/4"

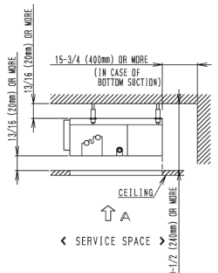
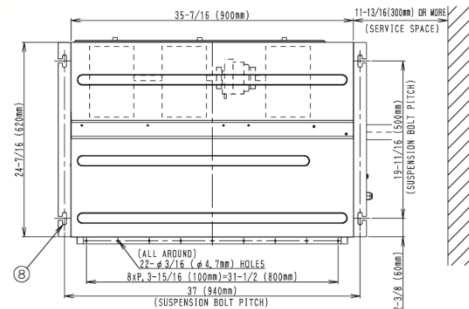

For 2MXSGVJU, 3MXS24JVJU and 4MXS32GVJU

2MXSGVJU

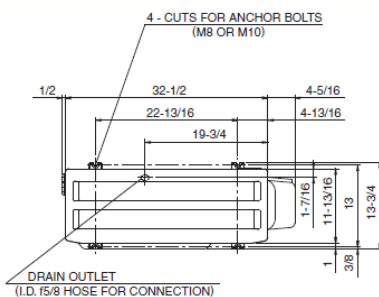

3MXS24JVJU & 4MXS32GVJU

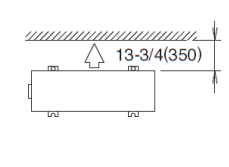
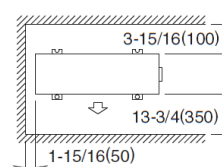
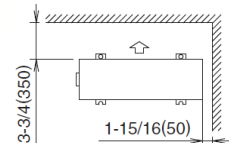
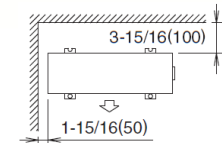
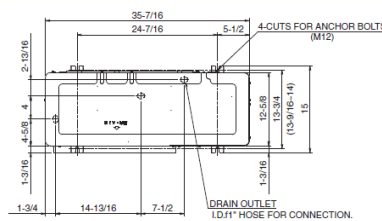

WARNINGS:

- Always use a licensed installer or contractor to install this product. Do not try to install the product yourself. Improper installation can result in water or refrigerant leakage, electrical shock, fire or explosion.
- Use only those parts and accessories supplied or specified by Daikin. Ask a licensed contractor to install those parts and accessories. Use of unauthorized parts and accessories or improper installation of parts and accessories can result in water or refrigerant leakage, electrical shock, fire or explosion.
- Read the User's Manual carefully before using this product. The User's Manual provides important safety instructions and warnings. Be sure to follow these instructions and warnings.

For any inquiries, contact your local Daikin sales office.



Use of the AHRI Certified™ mark indicates a manufacturer's participation in the certification program. For verification of certification for individual products, go to www.ahridirectory.org



Organization:
DAIKIN INDUSTRIES, LTD.
AIR CONDITIONING MANUFACTURING DIVISION
Scope of Registration:
THE DESIGN/DEVELOPMENT AND MANUFACTURE OF COMMERCIAL AIR CONDITIONING, HEATING, COOLING, REFRIGERATING EQUIPMENT, COMMERCIAL HEATING EQUIPMENT, RESIDENTIAL AIR CONDITIONING EQUIPMENT, HEAT RECLAIM VENTILATION, AIR CLEANING EQUIPMENT, MARINE TYPE CONTAINER REFRIGERATION UNITS, COMPRESSORS AND VALVES.



Organization:
DAIKIN INDUSTRIES (THAILAND) LTD.
Scope of Registration:
THE DESIGN/DEVELOPMENT AND MANUFACTURE OF AIR CONDITIONERS AND THE COMPONENTS INCLUDING COMPRESSORS USED FOR THEM.



All of the Daikin Group's business facilities and subsidiaries in Japan are certified under the ISO 14001 International standard for environmental management.

© 2012 Daikin Industries, Limited.

Daikin, Daikin AC Absolute Comfort, and its design, VRV, REFNET, Quaternity, Daikin Altherma are trademarks of Daikin Industries, LTD.

www.daikindifference.com

Distributor or Dealer Information:

Daikin AC (Americas), Inc.
1645 Wallace Drive, Suite 110
Carrollton, TX 75006
www.daikinac.com
866.4DAIKIN
972.245.1510

CCFMSUSE12-02R

For all equipment installation & application limitations please refer to the specific Engineering Data Books. Daikin's products are subject to continuous improvements. Daikin reserves the right to modify product design, specifications and information in this brochure without notice and without incurring any obligations.